



Model	Speed	Hz	HP	kW	SCFM	Pressure mbar	"H2O	Vacuum mbar	"H2O	Noise Level	Net Weight kg	lbs
RB3-101-1	1	60	1.1	.85	105	144	58	148	59	64 db(A)	15.5	35
RB3-101-3	3	50		.75	87	139	56	148	59	63 db(A)	15.5	35
RB3-105-2	2	60	1.5	1.1	105	190	76	182	73	64 db(A)	17	38
RB3-105-3	3	50		.9	87	188	75	168	67	63 db(A)	17	38
RB3-2-2	2	60	2	1.5	105	224	90	205	82	64 db(A)	19	43
RB3-2-3	3	50		1.3	87	202	81	180	72	63 db(A)	19	43

\*Refer to curves below for detailed performance data. Data subject to change without notice. Actual performance may vary by ±10%.

### STANDARD FEATURES

- Housing - Aluminum
- Impeller - Aluminum, dynamically balanced
- Direct drive impeller
- Shock absorbing mounting base
- Quiet operation - below OSHA limits
- Inlet & outlet silencers included
- Motor shaft seal standard
- IP 54 TEFC 2 pole squirrel cage ac motor
- 40 Deg C ambient
- Class H insulation 1.15 service factor
- Performance tested ANSI/AMCA210-85
- Voltage
  - 1 = 1/60/50/115/230
  - 2 = 1/60/50/230
  - 3 = 3/60/208-230/460 3/50/220/380

### 3/60/208-230/460 & 3/50/220/380

- RB3-101-3 replaces HB-329
- RB3-105-3 replaces HB-319
- RB3-2-3 replaces HB-339

### 1/60/115/230 & 1/50/220

- RB3-101-1 replaces HB-329-1
- RB3-2-2 replaces HB-339-1

### ACCESSORIES

Note: To obtain warranty coverage on the blower a relief valve and filter are required.

- Pressure Relief Valve RV-01
- Pressure Relief Valve RVA-01

- Vacuum Relief Valve RV-01
- Vacuum Relief Valve RVA-01

- Pressure Intake Air Filter F19P-150
- Vacuum Air Filter CSL-849-150HC



### TECHNICAL DATA

- [Available online www.all-star-usa.com]
- Performance Temperature Rise Curves
- AutoCad files
- Parts List
- Full load amperage



RoHS Compliant

**PRESSURE DATA CURVES ±10%**  
[See reverse side for Vacuum Curves]

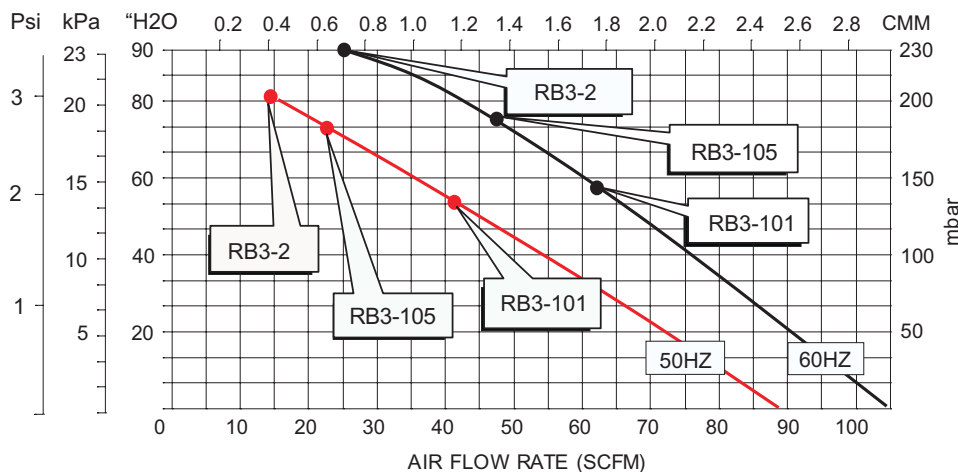

1.630.372.9222

**ALL STAR™**  
Regenerative Blowers  
Vacuum Pumps

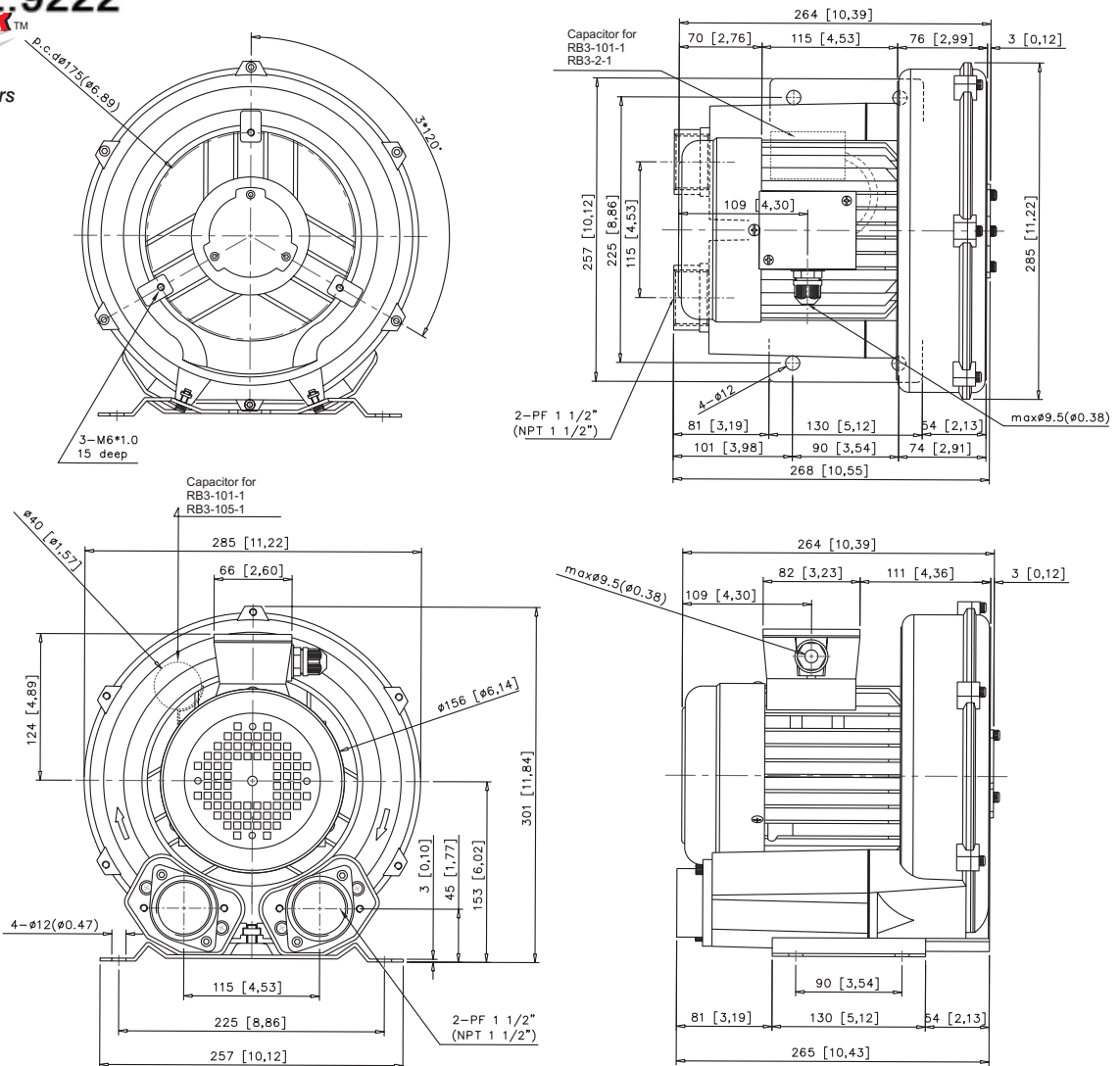

**VACUUM DATA CURVES**

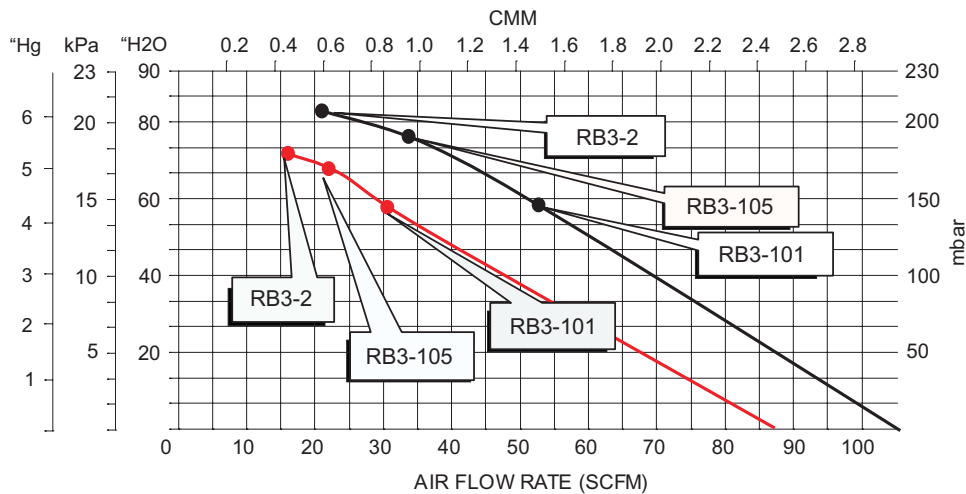

# Air

# Blower

# Services Inc.

www.airblowerservices.com

1.630.372.9222

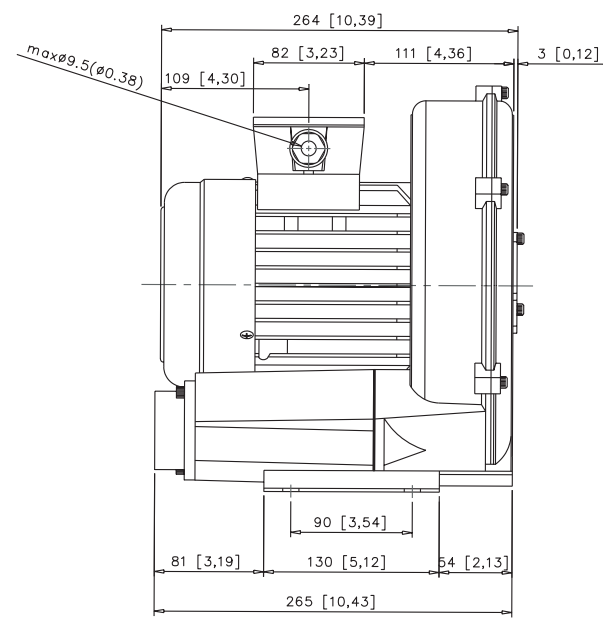
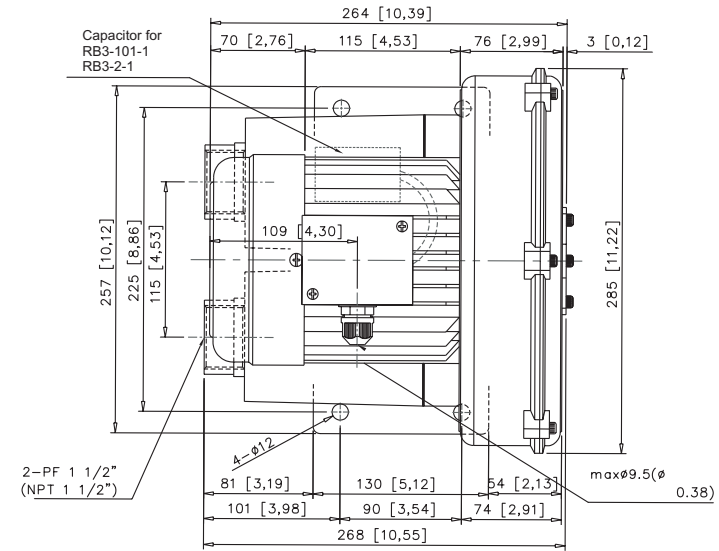
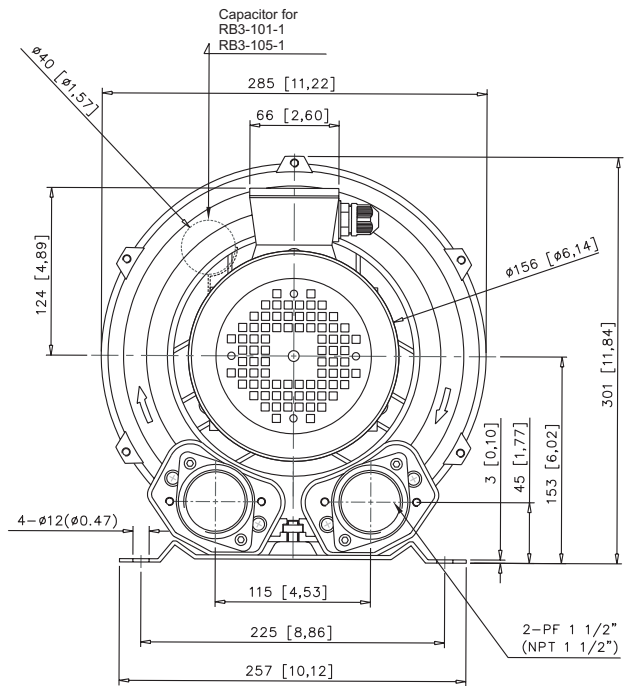
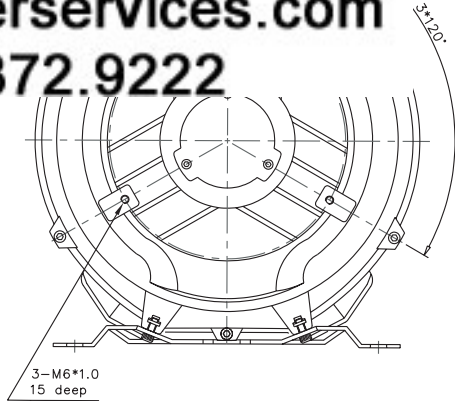

ALL-STAR PRODUCTS INC  
Cleveland Ohio Memphis Tennessee

REGENERATIVE BLOWER  
Model RB3 Series

December 30, 2006

## B3 Series - Pressure - Single Phase

60Hz

The technical data is based on 1 bar ( abs. ) free atmosphere and 20°C with Inlet air density 1.2kg/m<sup>3</sup>, ±10 %variance.

November 2006

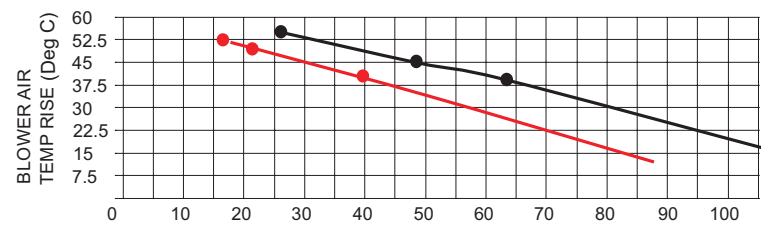
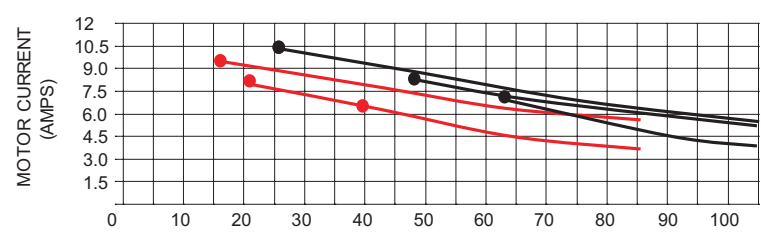
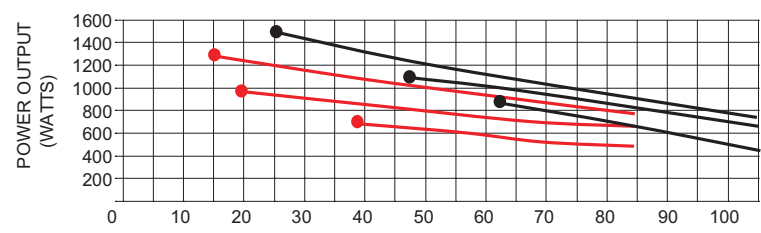
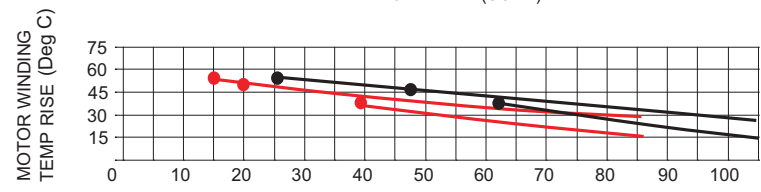
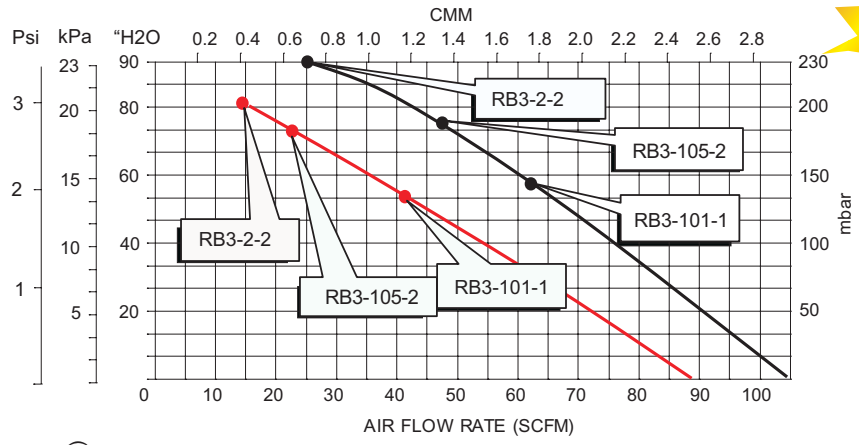

## B3 Series - Vacuum - Single Phase

60Hz

The technical data is based on 1 bar ( abs. ) free atmosphere and 20°C with Inlet air density 1.2kg/m<sup>3</sup>, ±10 %variance.

November 2006

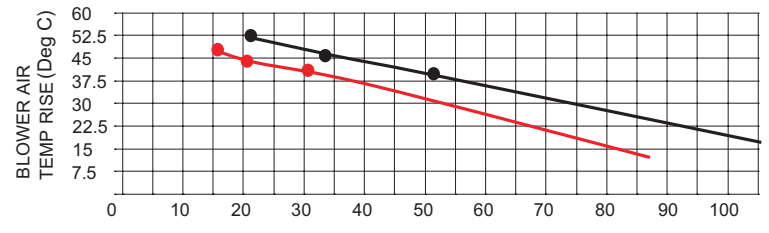
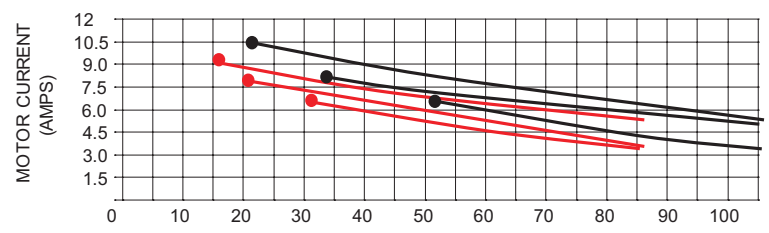
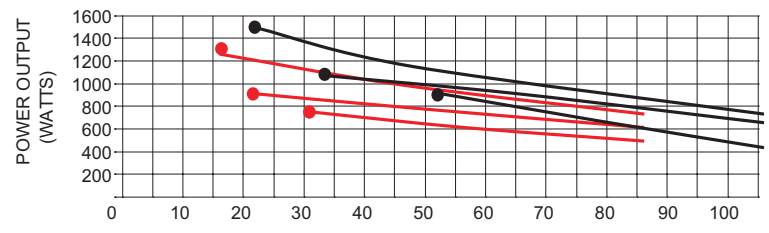
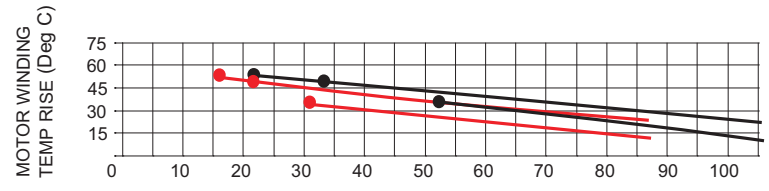
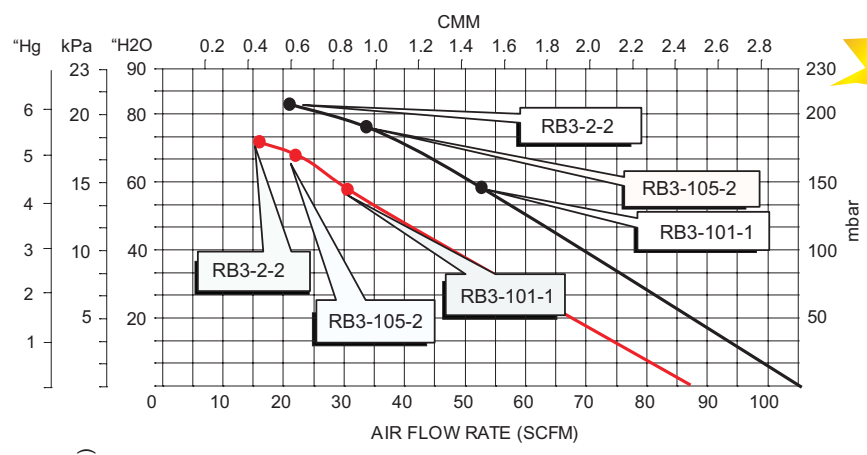

## B3 Series - Pressure - Three Phase

60Hz

The technical data is based on 1 bar ( abs. ) free atmosphere and 20°C with Inlet air density 1.2kg/m<sup>3</sup>, ±10 %variance.

November 2006

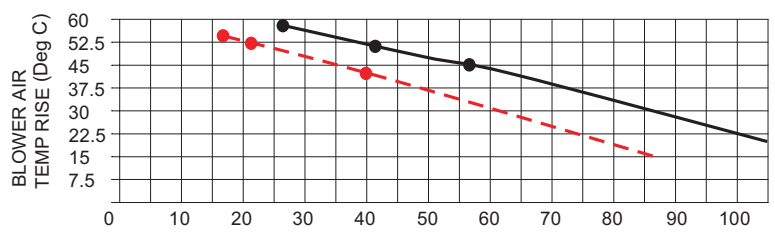
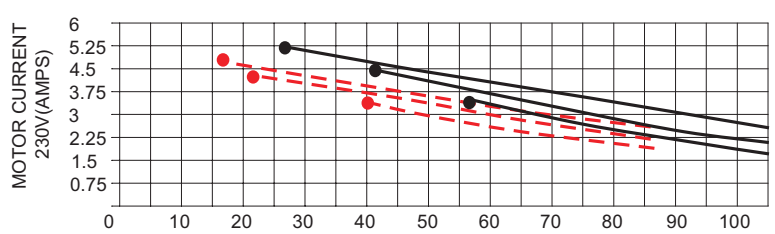
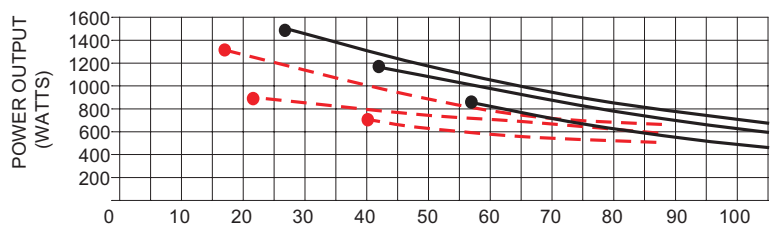
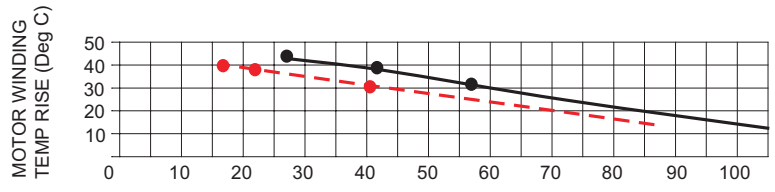
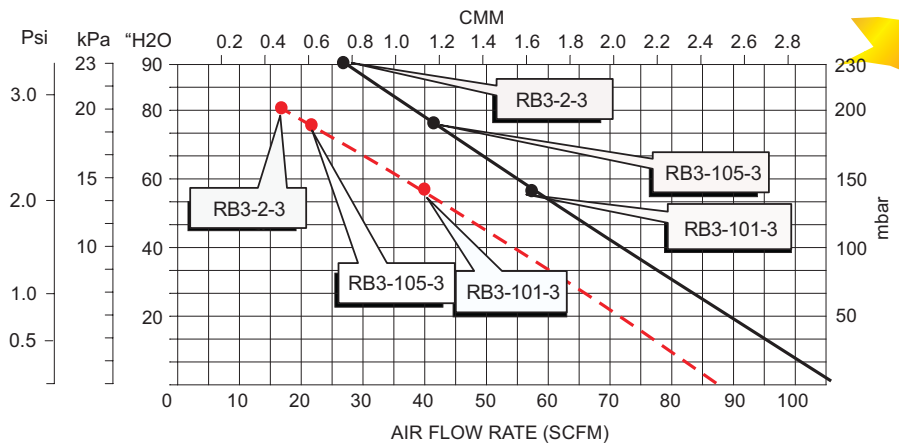

The technical data is based on 1 bar ( abs. ) free atmosphere and 20°C with Inlet air density 1.2kg/m<sup>3</sup>, ±10 %variance.

November 2006

