

Positive Blowers

Frames 404 thru 624

RAM™ stands for Reliability, Availability and Maintainability. Today, more than ever, Roots is committed to supplying our customers with reliable products manufactured with state-of-the-art CNC machine tools. Production and inventory are being scheduled and controlled to ensure these units will be available when you need them. Design improvements such as repositionable rugged steel mounting feet and die-cast aluminum drive end covers and gear covers help to reduce installation costs and make normal maintenance easier.

BASIC BLOWER DESCRIPTION

RAM™ rotary blowers are heavy-duty units designed with integral-shaft ductile iron impellers having an involute profile. The headplates and rigid, one-piece casing are grey iron, while the drive end cover and gear cover are aluminum. Carburized and ground alloy steel spur timing gears are taper mounted on the shafts, secured with a locknut. Cylindrical roller bearings are used on all units.

Piston rings reduce air leakage through the shaft openings in the headplates, and lip-type oil seals prevent lubricant from entering the air chamber. A hydrodynamic seal on the drive shaft prevents shaft seal oil leaks.

RAM rotary blowers incorporate thrust control, with splash oil lubrication at both ends of the blower.

All frame sizes are designed with detachable rugged steel mounting feet which permit in-field adaptability to either vertical or horizontal installation requirements.

The top shaft is extended for drive on side outlet blowers, and either shaft can be extended for drive on top or bottom outlet blowers.

WARRANTY PERIOD

Twenty-Four (24) months from date of original unit start-up or 30 months from date of original shipment, whichever occurs first.

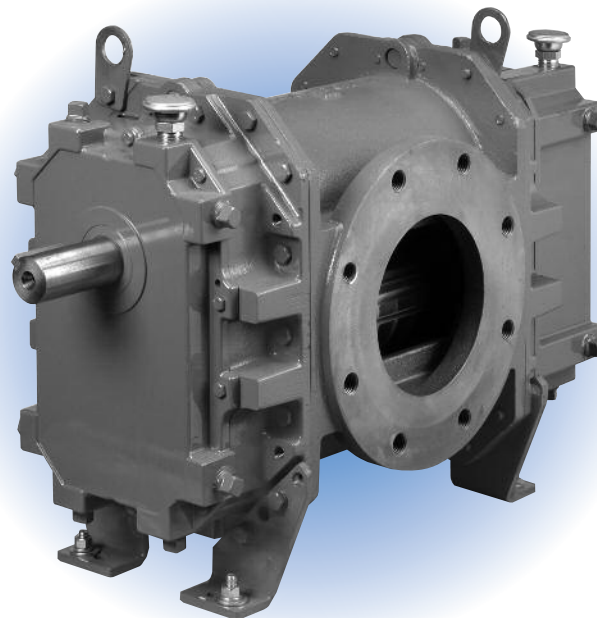

DESIGN AND CONSTRUCTION FEATURES

1. Horizontal and vertical configurations available
2. Improved volumetric efficiency and reduced operating temperatures
3. Alloy steel timing gears
4. Cylindrical roller bearings
5. Piston ring air seals
6. Lip-type, hydrodynamic oil seals,
7. Splash oil lubrication

OPERATING PRINCIPLE

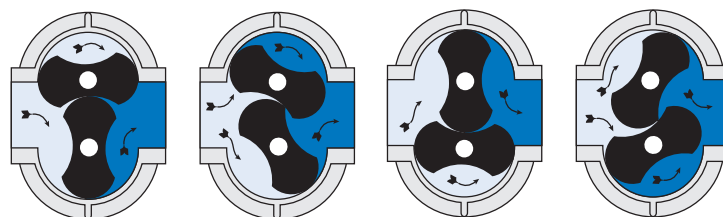

POSITION 1 POSITION 2 POSITION 3 POSITION 4

Two figure-eight lobe impellers mounted on parallel shafts rotate in opposite directions. As each impeller passes the blower inlet, it traps a definite volume of air and carries it around the case to the blower outlet, where the air is discharged. With constant speed operation the displaced volume is essentially the same regardless of pressure, temperature or barometric pressure. Timing gears control the relative position of the impellers to each other and maintain small but definite clearances. This allows operation without lubrication being required inside the air casing.

| FRAME SIZE | 5 PSI | | 10 PSI | | 12 PSI | | 15 PSI | | 18 PSI | | MAX VACUUM | | |
|------------|-------|------|--------|------|--------|------|--------|-----|--------|-----|------------|------|-------|
| | BHP | CFM | BHP | CFM | BHP | CFM | BHP | CFM | BHP | CFM | "HG | CFM | BHP |
| 404 | 6.9 | 123 | 8.6 | 116 | 10.3 | | | | | | 14.0 | 114 | 5.8 |
| | 12.3 | 255 | 15.1 | 248 | 17.9 | 239 | 22 | | | | 15.0 | 240 | 10.8 |
| | 17.8 | 370 | 21.5 | 364 | 25.2 | 355 | 30.7 | 347 | 36.2 | | 16.0 | 350 | 15.8 |
| 406 | 10.5 | 187 | 13 | 177 | 15.5 | | | | | | 14.0 | 173 | 8.8 |
| | 18.4 | 387 | 22.6 | 377 | 26.8 | 363 | 33.2 | | | | 15.0 | 365 | 16.2 |
| | 26.3 | 562 | 31.9 | 552 | 37.5 | 539 | 45.9 | 526 | 54.3 | | 16.0 | 531 | 23.7 |
| 409 | 15.6 | 279 | 19.4 | 264 | 23.2 | | | | | | 14.0 | 259 | 13.2 |
| | 27.3 | 579 | 33.6 | 564 | 39.9 | 544 | 49.3 | | | | 15.0 | 546 | 24.2 |
| | 38.7 | 842 | 47 | 827 | 55.4 | 806 | 68 | 788 | 80.5 | | 16.0 | 796 | 35.2 |
| 412 | 20.7 | 372 | 25.8 | 352 | 30.8 | | | | | | 14.0 | 344 | 17.6 |
| | 36.2 | 772 | 44.6 | 752 | 52.9 | 724 | 65.5 | | | | 15.0 | 728 | 32.1 |
| | 51.1 | 1121 | 62.2 | 1101 | 73.4 | 1074 | 90.1 | | | | 16.0 | 1060 | 46.6 |
| 418 | 31.1 | 559 | 38.7 | | | | | | | | 14.0 | 517 | 26.4 |
| | 54.1 | 1159 | 66.7 | | | | | | | | 15.0 | 1092 | 48.1 |
| | 76.3 | 1684 | 93.0 | | | | | | | | 16.0 | 1591 | 69.8 |
| 616 | 32.6 | 524 | 40.6 | 486 | 48.6 | | | | | | 13.0 | 501 | 25.7 |
| | 49.4 | 982 | 61.3 | 943 | 73.2 | | | | | | 14.0 | 929 | 41.7 |
| | 88.6 | 1968 | 108.4 | 1930 | 128.2 | 1878 | 157.9 | | | | 16.0 | 1851 | 81.8 |
| 624 | 49.1 | 786 | 61.1 | | | | | | | | 13.0 | 751 | 38.8 |
| | 75.0 | 1473 | 92.8 | | | | | | | | 14.0 | 1394 | 63.0 |
| | 137.1 | 2953 | 166.8 | | | | | | | | 16.0 | 2777 | 124.8 |

Notes: 1. Pressure ratings based on inlet air at standard pressure of 14.7 psia, standard temperature of 68° F, and specific gravity of 1.0.
2. Vacuum ratings based on inlet air at standard temperature of 68° F, discharge pressure of 30" Hg and specific gravity of 1.0.

OUTLINE DRAWING & DIMENSIONAL TABLE

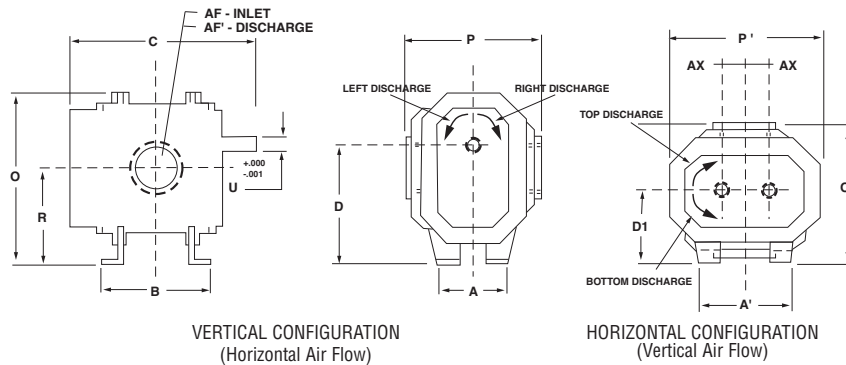

| FRAME SIZE | A | A' | B | C | Drive Shaft Location | | O | O' | P | P' | R | U | Keyway | AF Inlet Diameter | AF' Discharge Diameter | AX | Approx. NetWt (lbs) |
|------------|-------|-------|-------|-------|----------------------|------|-------|-------|-------|-------|-------|-------|------------|-------------------|------------------------|------|---------------------|
| | | | | | D | D1 | | | | | | | | | | | |
| 404 | 8.00 | 11.00 | 8.75 | 18.50 | 11.25 | 7.50 | 16.63 | 13.50 | 12.00 | 15.25 | 9.00 | 1.500 | .375 x.188 | 3.0 NPT | 3.0 NPT | 2.25 | 200 |
| 406 | 8.00 | 11.00 | 10.75 | 20.50 | 11.25 | 7.50 | 16.63 | 13.50 | 12.00 | 15.25 | 9.00 | 1.500 | .375 x.188 | 4.0 NPT | 4.0 NPT | 2.25 | 230 |
| 409 | 8.00 | 11.00 | 13.75 | 23.50 | 11.25 | 7.50 | 16.63 | 13.00 | 11.00 | 15.25 | 9.00 | 1.500 | .375 x.188 | 4.0 NPT | 4.0 NPT | 2.25 | 270 |
| 412 | 8.00 | 11.00 | 16.75 | 26.50 | 11.25 | 7.50 | 16.63 | 13.00 | 11.00 | 15.25 | 9.00 | 1.500 | .375 x.188 | 6.0 FLG | 6.0 FLG | 2.25 | 330 |
| 418 | 8.00 | 11.00 | 22.75 | 32.50 | 11.25 | 7.50 | 16.63 | 13.00 | 11.00 | 15.25 | 9.00 | 1.500 | .375 x.188 | 8.0 FLG | 8.0 FLG | 2.25 | 410 |
| 616 | 10.00 | 16.00 | 20.75 | 32.44 | 15.00 | 9.00 | 22.00 | 16.25 | 14.50 | 20.00 | 12.00 | 2.000 | .500 x.250 | 8.0 FLG | 8.0 FLG | 3.00 | 650 |
| 624 | 10.00 | 16.00 | 28.75 | 40.44 | 15.00 | 9.00 | 22.00 | 16.25 | 14.50 | 20.00 | 12.00 | 2.000 | .500 x.250 | 10.0 FLG | 10.0 FLG | 3.00 | 775 |

Notes: 1. All dimensions are in inches. 2. Do not use for construction.

Dresser Roots

Houston, Texas Headquarters • U.S. Toll Free Phone: 1-877-363-ROOT(S) (7668) • Direct Phone: +1 832-590-2600
 Connorsville, Indiana Operations • U.S. Toll Free Phone: 1-877-442-7910 • Direct Phone: +1 765-827-9285
 United Kingdom Operations • Phone: +44 (0) 1695 52600
 USA/Canada Sales • Phone: +1 773-444-3360
 Houston, Texas Factory Service • Phone: +1 713-896-4810
 Mexico City Sales and Factory Service • Phone: +52 55 5889 5811
 Dubai Sales and Factory Service • Phone: +971 4-8830831
 Malaysia Sales • Phone: +60 3 2163 0480
 China Sales • Phone: +86 10 8486 2440
 Shanghai Factory Service • Phone: +86 21 5858 7638

