

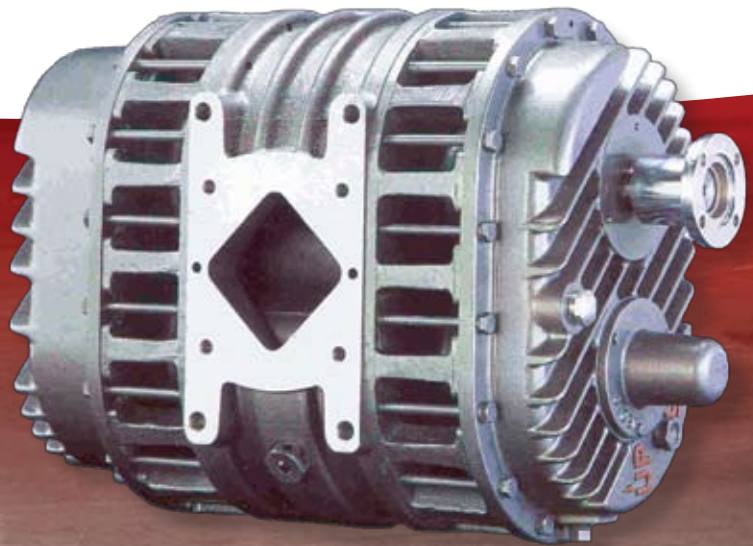

**D807 & D907**

Dry Bulk Truck Blowers



Experience Proven Results™

## High Performance Rotary Lobe Blowers

GD Dry Bulk Truck Blowers are the most versatile truck blowers available. D807 is the first truck blower in the industry to offer 20 psi continuous operation. Fitting a D807/907 on your tractor means it will be ready to do any job necessary. Keep your fleet size in control and make dispatching easy. High-pressure capability and wide speed range make these blowers ideal for:

- Cement
- Sand
- Fly ash
- Flour
- Sugar
- Grain
- Pebble lime
- Plastic pellets

- Airflow up to 1300 cfm
- Pressure up to 20 psig
- Vacuum up to 17" Hg
- 12/18 Months warranty

### Features

- Up to 20 psig continuous duty pressure rating (D807 only)
- Oil lubrication at both ends reduces bearing temperature and eliminates the need for greasing
- Diamond port design greatly reduces noise and airflow pulsations
- Heat dissipation ribbing on body, end plates, and gear cases provides cooler discharge temperatures and allows for tighter tolerances
- Easy Installation with vertical mounting kit
- Twin drive shaft offers either direction of rotation and ensures correct alignment of drive shaft upon installation
- Packaged units available for on-site product transfer requirements through dedicated distributor networks

### Over Temperature & Over Pressure Protection

- Plug relieves 5–6 psi along with a 60–80° F drop in temperature, allows continued operation at lower pressure
- One plug fitted on suction side and one on the delivery side
- Reduces the likelihood of accidental overheating
- Consistent release temperature from each plug
- Visual activation indicator



### Geared for Higher Efficiency

- Dynamically balanced efficient rotors for cooler operation
- Precision ground helical gears keyed to shaft provide positive timing and easy maintenance

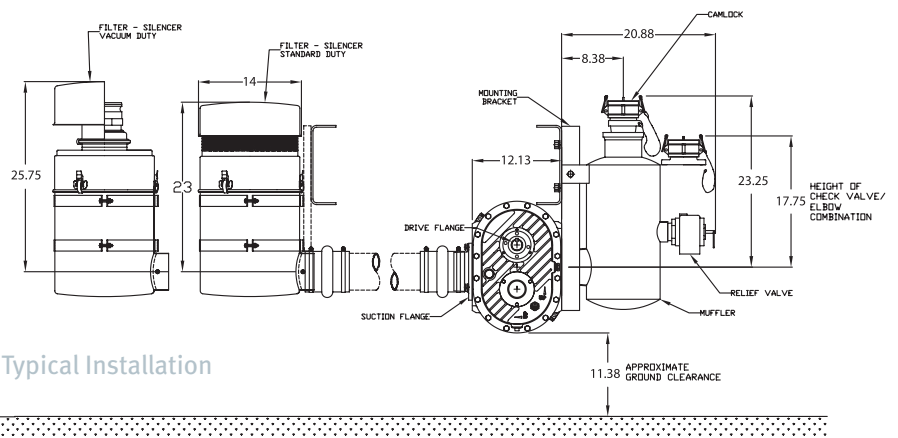
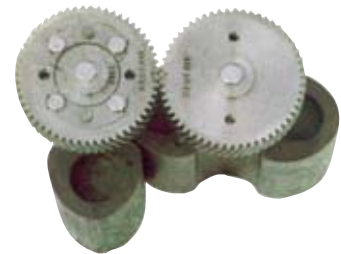

Typical Installation

# & Dimensional Data

## D807 Performance Specifications

Pressure	1800 RPM		2000 RPM		2200 RPM		2400 RPM		2600 RPM		2800 RPM		3000 RPM	
PSI	CFM	HP	CFM	HP	CFM	HP	CFM	HP	CFM	HP	CFM	HP	CFM	HP
2	578	8	650	9	722	9	794	10	864	11	936	12	1010	13
4	548	13	620	15	692	16	764	17	838	20	910	21	983	23
6	525	19	597	21	669	23	741	25	812	28	884	30	956	32
8	506	24	578	27	650	30	722	32	794	36	865	39	937	42
10	489	30	561	34	633	37	705	40	776	44	846	47	918	51
12	473	36	545	40	618	44	690	48	760	52	831	56	903	61
14	459	42	531	46	603	51	676	56	744	60	816	65	888	71
16	446	47	518	52	590	58	662	63	730	69	803	74	875	80
18	435	53	508	59	580	65	652	71	716	77	790	83	862	89
20	424	59	496	65	568	72	640	78	706	85	778	92	850	98

Vacuum	1800 RPM		2000 RPM		2200 RPM		2400 RPM		2600 RPM		2800 RPM		3000 RPM	
IN HG	CFM	HP	CFM	HP	CFM	HP	CFM	HP	CFM	HP	CFM	HP	CFM	HP
2	600	5	693	5	736	6	812	7	884	7	956	8	1030	9
4	573	8	656	8	714	10	788	11	852	11	934	12	1006	13
6	545	10	618	11	691	13	764	14	820	15	912	16	982	17
8	527	13	600	14	673	17	742	18	809	19	891	21	962	22
10	509	16	582	17	654	20	720	21	798	23	870	25	942	27
12	482	19	559	21	632	23	697	25	775	27	847	30	919	32
14	454	21	536	24	609	26	673	28	752	31	824	34	896	36
16	436	22	515	27	571	29	655	31	732	34	803	38	875	40
17	418	25	494	29	538	31	636	34	712	37	782	41	854	43

Performances based on inlet air at standard temperature of 68°F, and ambient pressure of 14.7 psia and 36% relative humidity. Dimensions shown in inches.

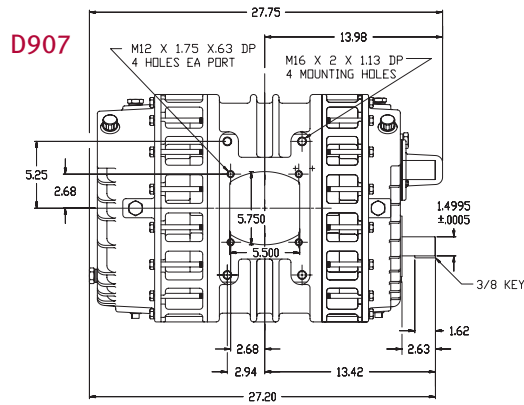
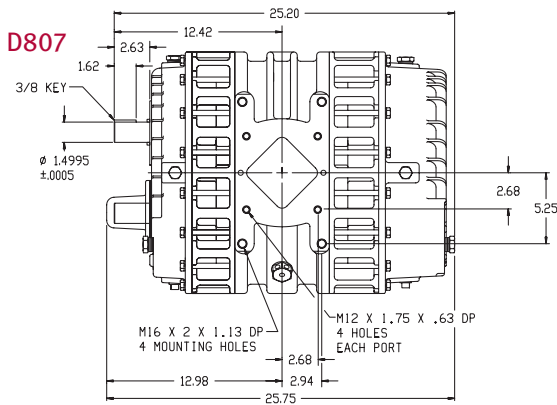

## D907 Performance Specifications

Pressure	1800 RPM		2000 RPM		2200 RPM		2400 RPM		2600 RPM		2800 RPM		3000 RPM	
PSI	CFM	HP	CFM	HP	CFM	HP	CFM	HP	CFM	HP	CFM	HP	CFM	HP
2	733	9	826	10	918	11	1011	12	1104	13	1197	14	1290	15
4	690	17	783	18	876	20	969	22	1062	24	1155	26	1248	28
6	658	24	751	26	843	29	936	31	1029	34	1122	37	1215	40
8	630	31	723	35	816	38	909	42	1002	46	1095	50	1188	54
10	606	38	699	43	792	47	885	51	978	56	1071	61	1164	66
12	584	46	677	51	770	56	863	61	956	66	1049	71	1142	76
14	564	53	657	59	750	65	843	71	936	77	1029	84	1122	91
16	546	60	638	67	734	74	829	81	923	88	1017	96	1111	104

Vacuum	1800 RPM		2000 RPM		2200 RPM		2400 RPM		2600 RPM		2800 RPM		3000 RPM	
IN HG	CFM	HP	CFM	HP	CFM	HP	CFM	HP	CFM	HP	CFM	HP	CFM	HP
2	760	6	855	7	945	8	1040	8	1133	9	1226	9	1319	10
4	730	10	823	11	975	12	1010	13	1103	14	1196	14	1289	15
6	700	13	790	14	885	15	980	17	1073	19	1166	19	1259	20
8	670	17	763	18	853	20	950	22	1043	24	1136	24	1229	25
10	640	20	735	22	830	24	920	27	1013	29	1106	29	1199	30
12	600	24	705	26	800	28	890	32	983	34	1076	34	1169	35
14	560	28	675	30	770	33	860	36	953	39	1046	39	1139	40
16	544	31	648	33	740	37	833	40	926	44	1019	44	1112	45
17	527	33	620	36	710	40	805	44	900	49	995	49	1090	50

Performances based on inlet air at standard temperature of 68°F, and ambient pressure of 14.7 psia and 36% relative humidity. Dimensions shown in inches.

its  
work

- Bolt on camlock 3" or 4" available
- 2" relief valve screws directly in body
- Easy installation using universal mounting bracket
- Drive flange 1300 series

**Acoustically Tuned Filter Silencer**

- Radialip filter element giving greater sealing in canister
- Removable foam pre-cleaner element for cleaning and reuse, in addition the foam pre-cleaner greatly adds to noise abatement and service life
- Filter lid and screen designed to give minimal restriction and keep out water
- O-Ring type gasket seals top and bottom assemblies for maximum protection
- Powder coated inside and out
- Restriction indicator available

**Acoustically Designed  
Easy Bolt On Discharge Silencer**

- 2" NPT port for relief valve in housing
- Port for optional pressure gauge
- Available in Stainless Steel
- Double wall construction with 1000° F packing totally enclosed to prevent any down line contamination
- Temperature gauge

**Packaged Units**

Self contained package units with electric motor, diesel engine or hydraulic drive can be supplied through Gardner Denver distribution networks.



**Gardner  
Denver®**

www.GardnerDenverProducts.com mobilesolutions@gardnerdenver.com

Gardner Denver, Inc. 1800 Gardner Expressway, Quincy, IL 62305  
 Customer Service Department  
 Telephone: (800) 682-9868 FAX: (217) 221-8780



Member



©2009 Gardner Denver, Inc. Printed in U.S.A. GDT-807-907 1st Ed. 8/09  
 Supersedes GDD-2-101/GDD-2-102

Please recycle after use.